

A-A

LTR	Part Name	Material	Description	QTY
1	Housing	LCP UL94V-0	260°C for 10 Seconds, Initial : 1000M Ohms Min.	1
2	Contact	Bronze CS191	Current Rating : 0.5 A Initial : 30m Ohms Max.	XX

Temperature Rating : -40°C ~ +105°C.
Dielectric Withstanding Voltage : 300 V AC/Min

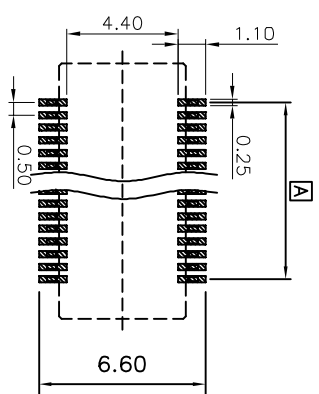

▨ : STAND OFF AREA

Circuit No.	Dimensions			
	A	B (A±2.1)	C (A±0.95)	D (A±3.1)
2*10P	4.50	6.60	5.45	7.60
2*15P	7.00	9.10	7.95	10.10

C 28 00 XX -15

Number of Contact
20, 30 Contact

Series No.
MATE WITH C2800XX-14

THIS DRAWING IS A CONTROLLED DOCUMENT.

DIMENSIONS: MM		TOLERANCES UNLESS OTHERWISE SPECIFIED:	
0 PL/C	± -	DMN	尹晚開
1 PL/C	± 0.30	CHK	楊廣文
2 PL/C	± 0.20	APVD	林振偉
3 PL/C	± 0.15	PRODUCT SPEC	01SEP2023
4 PL/C	± - ±.3	QUALIFICATION TEST REPORT	
FINISH ANGLES		WEIGHT	
SEE NOTE		CUSTOMER DRAWING	

CHUFON TECH CO., LTD

PH0.5 BT0B H1.45 SERIES PIN 公座

SIZE CASE CODE DRAWING NO
A3 00779 C280000-15

SCALE SHEET 1 OF 1 REV A0